

GA184A

## THE TORQUE MULTIPLIER

The mechanical advantage in the use of the torque multiplier is derived from the planetary transmission within the gear head of the tool. With the torque multiplier reaction bar in a fixed position against a stationary object, and the input tool driving, the socket and fastener sees forces equaling the ratio of the torque multiplier or combination of multipliers being used times the input force. Due to frictional losses in the gear train, a torque loss factor of 10 to 20% should be anticipated.

In breaking a difficult or frozen fastener, it is important to place the torque multiplier reaction bar against a strong stationary object since the reac-

tion bar rotation is opposite the output force rotation. See the figure below.

**CAUTION:** Force must not exceed the rated capacity of the specific torque multiplier being used since failure and sudden release of the input drive may result.

Torque multipliers must not be used in conjunction with impact tools because high shock loads may damage the tool.

**CAUTION** To assure accurate torque readings, the Snap-on TEX Type Torqometer must be placed between the torque multiplier and the socket (see the figure below). If the torque multiplier is placed between the socket and the torque wrench, a 10-25% loss in torque reading will result.

### Mathematics of the Torque Multiplier

In most wrench applications the force relationship is expressed by the formula:

$$F \times D = T$$

(FORCE x DISTANCE = TORQUE)

where: F equals turning force in pounds applied by the operator,  
D equals length of wrench handle in inches, feet or meter,  
T equals total force applied to wrench head in pound-inches, pound-feet, or Newton-meter.

When the torque multiplier is used, its mechanical advantage applies a factor to the above equation as follows:

$$F \times D \times \text{Multiplier Factor} = T \times \text{Multiplier Factor}^*$$

It can thus be seen that the same applied force F results in several times the total turning force when the torque multiplier is used.

*\*In actual operation this factor is reduced 10 to 20% due to normal losses in the tool head.*

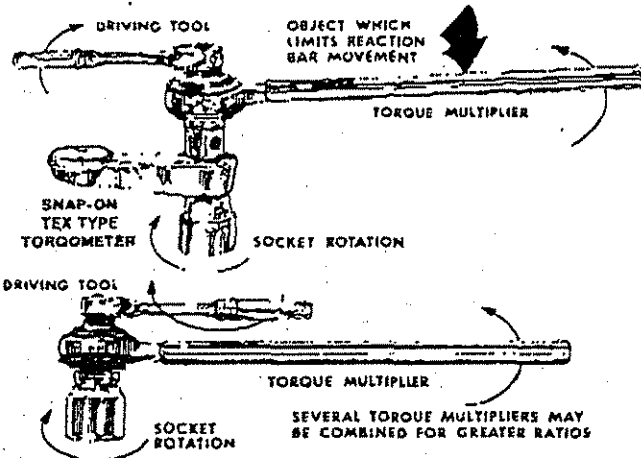

### Service Instructions Models GA184A, GA185, GA186, GA187, GA189 and GA190

**CAUTION:** Wear safety goggles when using punches and striking tools.

1. On model GA190 only, remove the ratchet assembly by backing off the set screw.
2. Remove the four socket head cap screws (item 12).
3. With a pin punch, drive the input pinion (item 1) in the direction indicated on the parts diagram, noting the position of item 11. When item 11 is completely clear of item 10, all further disassembly can be accomplished without the use of tools.
4. Note the location of item 7 during disassembly. These washers are retainers for the input pinion (item 1) and must be replaced in exactly the same position.
5. After disassembly, carefully wash and inspect each part for excessive wear or damage. Replace worn or damaged parts as necessary.
6. In reassembling the unit it is very important that all bearing surfaces be completely coated with Alma 50C lubricant\* and an additional liberal amount packed in all the gear teeth.
7. Reassembly starts with item 1 and progresses in order as indicated in the parts diagram, ending with item 12, the latter being the socket head cap screws which must be very tight.
8. Inspect by turning the input pinion (item 1). If the wrench cannot be

turned, the retainer washers (item 7) are improperly installed. The washer must be directly opposite from each other and in the recessed counter bores of item 3 (some models only).

### Service Instructions—Model GA191

**CAUTION:** Wear safety goggles when using punches and striking tools.

1. Loosen cap screws at output stub approximately 1/2". Place head of loosened screws down on two support rails and force down the outer housing to release internal components.
2. Remove screws from the first stage carrier ring (input side).
3. Remove first stage input assembly. This assembly removal may require light hammering with a soft face mallet.
4. To disassemble the first stage input assembly, remove the screws on the output side, and then, using a soft metal bar, strike the female socket firmly. This will cause the entire first stage assembly to come apart.
5. After disassembly, carefully wash and inspect each part for excessive wear or damage. Replace worn or damaged parts as necessary.
6. In reassembling the unit it is very important that all bearing surfaces be completely coated with Alma 50C lubricant\* and an additional liberal amount packed in all gear teeth. There are two retainers (larger diameter) and two spacers in the first stage assembly. Be certain to position the retainers opposite each other when reassembling.

\* A Lubrication pack (GA184-17) is available from your SNAP-ON representative.

**SERVICE INSTRUCTIONS - PARTS LISTS**

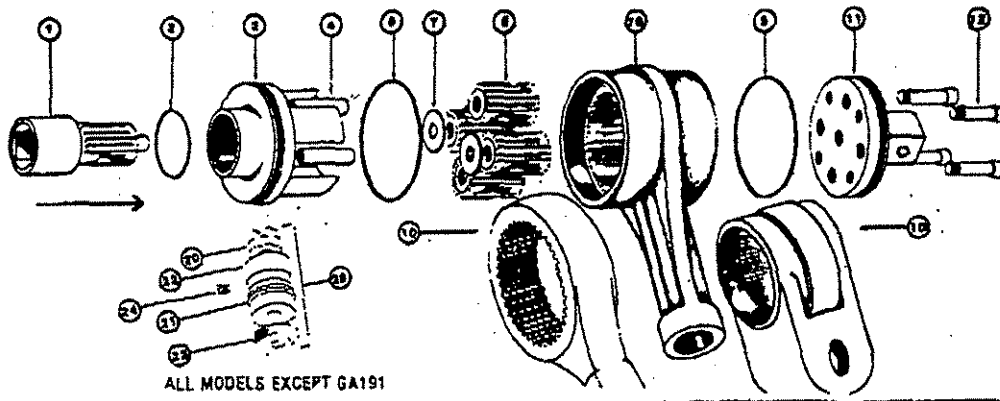

ALL MODELS EXCEPT GA191

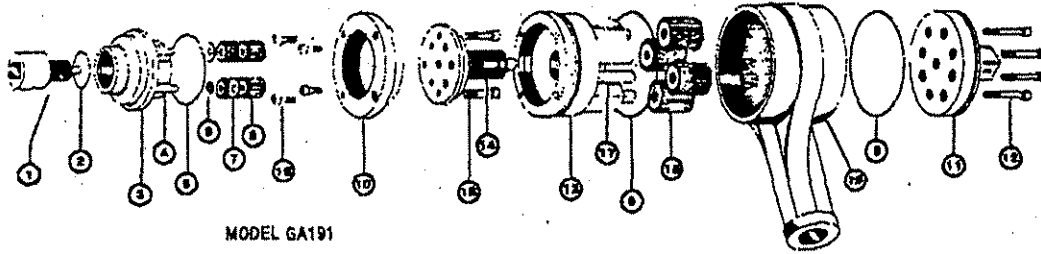

MODEL GA191

DRAWING ITEM	PART DESCRIPTION	PART NO. GA184A	PART NO. GA185	PART NO. GA 190	PART NO. GA191	PART NO. GA189	PART NO. GA187	PART NO. GA188
1.	Input Pinion	-02	-02	-02	-02	-02	-02	-02
2.	Input "O" Ring	-10	-10	-10	-10	-10	-10	-10
3.	Input Carrier	-04	-04	-04	-04	-04	-04	-04
4.	Dowel Pins (4)	-08	-08	-08	-08	-08	-08	-08
5.	Housing "O" Ring (2)	-09	-09	-09	-09	-09	-09	-09
6.	Carrier "O" Ring				-27			
7.	Input Retainer	(1)-07	(2)-07	(2)-07	(2)-07	(2)-07	(4)-07	(2)-07
8.	Planet Pinion (4)	-03	-03	-03	-03	-03	-03	-03
9.	Spacer (2)		-28	-26	-26			
10.	Housing	-01	-01	-01	-01	-01	-01	-01
11.	Output Stub	-05	-05	-05	-05	-05	-05	-05
12.	Special Screw (4)	-06	-06	-06	-06	-06	-06	-06
13.	Carrier, 2nd				-28			
14.	Sun Pinion, 2nd				-29			
15.	Planet Pinion, 2nd (4)				-30			
16.	Housing, 2nd				-31			
17.	Dowel, 2nd (4)				-32			
18.	Screw, Coupling (4)				-33			
19.	Screw (4)				-34			
20.	Pawl			-20				
21.	* Spring, Pawl			-21				
22.	Sleeve, Pawl			-22				
23.	Knob, Ratchet			-23				
24.	Screw, Retainer			-24				
25.	Asy. Ratchet			-25				
26.	* Reaction Bar	-16	-16	-16	-16	-16	-16	-16
27.	* Lube Pack	-17	-17	-17	-17	-17	-17	-17

\* Not Shown

Model	Output Capacity	Input Drive	Output Drive	Ratio*	Approx. Wgt.
GA184A	1000 LBS. FT. (1356 N.m)	1/2"	3/4"	4 to 1	7 LBS. (3.2 KG)
GA-185	2000 LBS. FT. (2712 N.m)	3/4"	1"	4 to 1	14 LBS. (6.4 KG)
GA190	2000 LBS. FT. (2712 N.m)	3/4"	1"	4 to 1	15 LBS. (6.9 KG)
GA191	3000 LBS. FT. (4067 N.m)	3/4"	1 1/2"	14.3 to 1	30 LBS. (14 KG)

Model	Output Capacity	Input Drive	Output Drive	Ratio*	Approx. Wgt.
GA186	4000 LBS. FT. (5423 N.m)	1"	1 1/2"	4.33 to 1	30 LBS. (14 KG) †
GA187	8000 LBS. FT. (10847 N.m)	1"	1 1/2"	4.6 to 1	47 LBS. (21 KG)
GA189	12000 LBS. FT. (16270 N.m)	1"	2 1/2"	6 to 1	73 LBS. (33 KG)

\* Ratios will be reduced between 10-25% because of frictional losses in the head.

Be sure to mention Model and Serial No. when ordering parts.

**Snap-on Tools Corporation**

Kenosha, Wisconsin 53140

Printed in U.S.A.  
12-87-1M